

GULMAY

FC 100HP Technical Specification

kV Range	10 - 100	mA Range	0 – 16 within a 1000W limit
Line Regulation	< 0.2% change for an input change of +/- 10% in 2 Seconds	Load Regulation	< 0.2% change for a load change from 100uA to 10mA in 2 Seconds
Output Drift	0.1% over 8 hours after initial 30 minute equalisation	Output Risetime	20kV per second.
Output accuracy	+/- 2.5%	Filament Supply	Up to 9V at 4.5A
Output Connector	R10 or R24	Environmental Conditions	10 to 35 Deg. C at up to 80% Humidity, non condensing
Input Voltage	220 V AC +/- 10% 47 – 63 Hz	Multiplier Frequency	25kHz
Size mm (WxLxH)	360 X 613 X 482	Input Current	10.6A at 220V AC
		Weight (Kg)	102

General Information

As Metal Ceramic x-ray tubes have evolved Gulmay has developed its product in 3 phases to culminate in a single drive platform capable of powering up to 1000 W and with options of single or dual filament and unipolar or bipolar tube connection. The current drive platform is based on the 'FC' family using IGBT's at 25 kHz with reduced air inflow to facilitate operation in harsher conditions.

- The 'HP' derivative is capable of 1000 W.
- Single and dual filament versions are available.
- All units connect to the X-ray tube with industry standard rubber coned connectors.
- All units are capable of operation with external and embedded controllers.
- Oil is used as an insulation medium together with epoxy encapsulated sub assemblies. No vacuum impregnation is required and local servicing is possible.

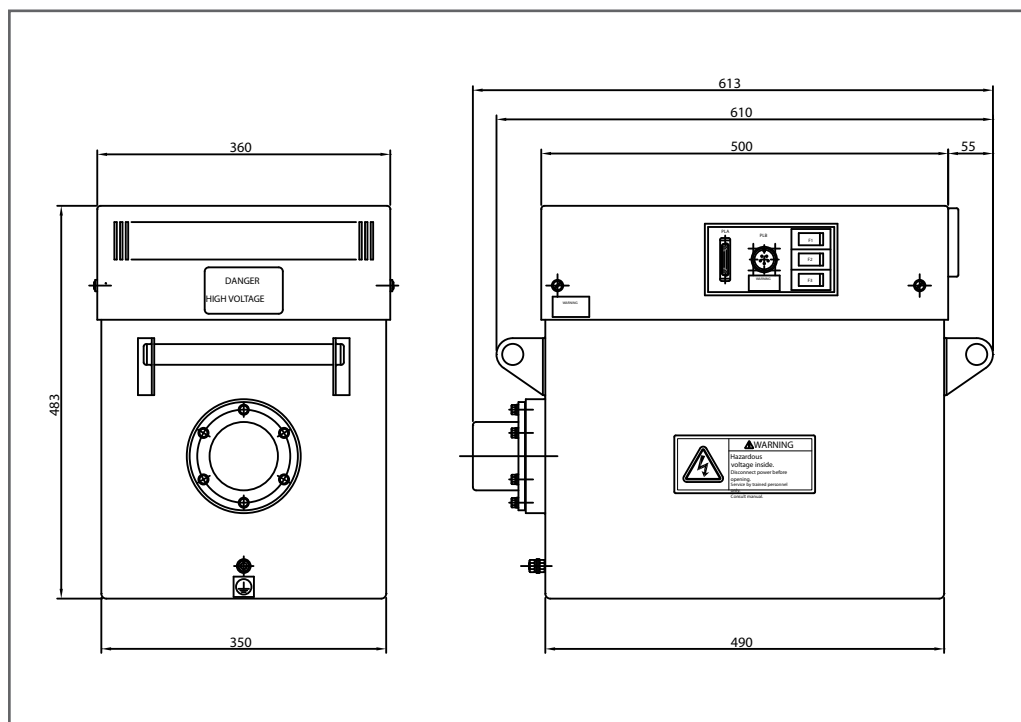

THE DIFFERENCE IS IN
THE DESIGN