



CP 450 Technical Specification

kV Range	40 - 450	mA Range	0 – 20 reduced by X-Ray tube power limits
Line Regulation	< 0.2% change for an input change of +/- 10% in 2 Seconds	Load Regulation	< 0.2% change for a load change from 100uA to 10mA in 2 Seconds
Output Drift	0.1% over 8 Hours after initial 30 Minute equalisation	Output Risetime	40kV per second.
Output accuracy	+/- 2.5%	Filament Supply	Up to 9V at 4.5A
Output Connector	R30	Environmental Conditions	10 to 35 Deg. C at up to 80% Humidity, non condensing
Input Voltage	220 V AC +/- 10% 47-63 Hz	Multiplier Frequency	25 KHz
Cathode Generator Size mm (WxLxH)	435 x 813 x 780	Input Current	27A at 220V AC
Anode Generator Size mm (WxLxH)	528 x 813 x 780	Cathode Generator Weight (Kg)	240
		Anode Generator Weight (Kg)	190

General Information

The CP Series has continued to evolve over its product life and is available in the range of 100 to 450 kV with both unipolar and bipolar options. CP series generators are available in single or dual focus configurations. The CP series uses 25 kHz for EHT generation and the family of products offers low ripple and low drift.

- All units connect to the x-ray tube with industry standard rubber coned connectors designated R10, R24 or R30.
- All units are capable of operation with external and embedded controllers.
- Oil is used as an insulation medium together with epoxy encapsulated sub assemblies. No vacuum impregnation is required and local servicing is possible.

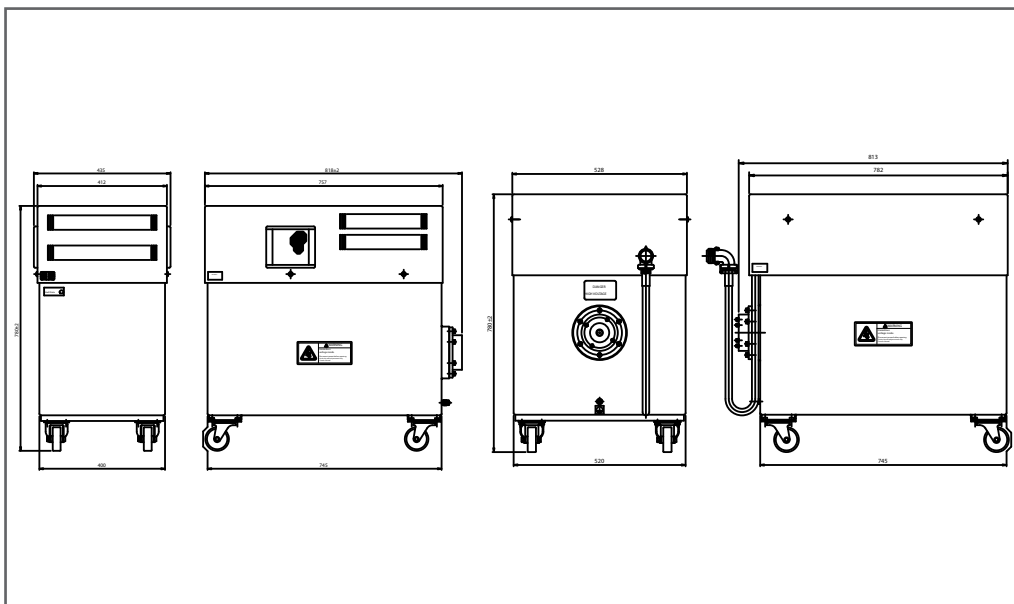

THE DIFFERENCE IS IN
THE DESIGN

Gulmay Limited

St. Ann's House, St. Ann's Road,
Chertsey, Surrey, KT16 9EH
T: +44 (0)1932 57 0600 F: +44 (0)1932 56 8700
E: sales@gulmay.co.uk